

LOC	DIST	REVISIONS			
HM	00	REV	DATE	BY	APPD
		A	NSD07-041	23MAY2007	JM SH
		B	REV: ECO-07-022804	10OCT2007	GG SH
		C	REV: ECO-09-013355	23JUN2009	GG DC

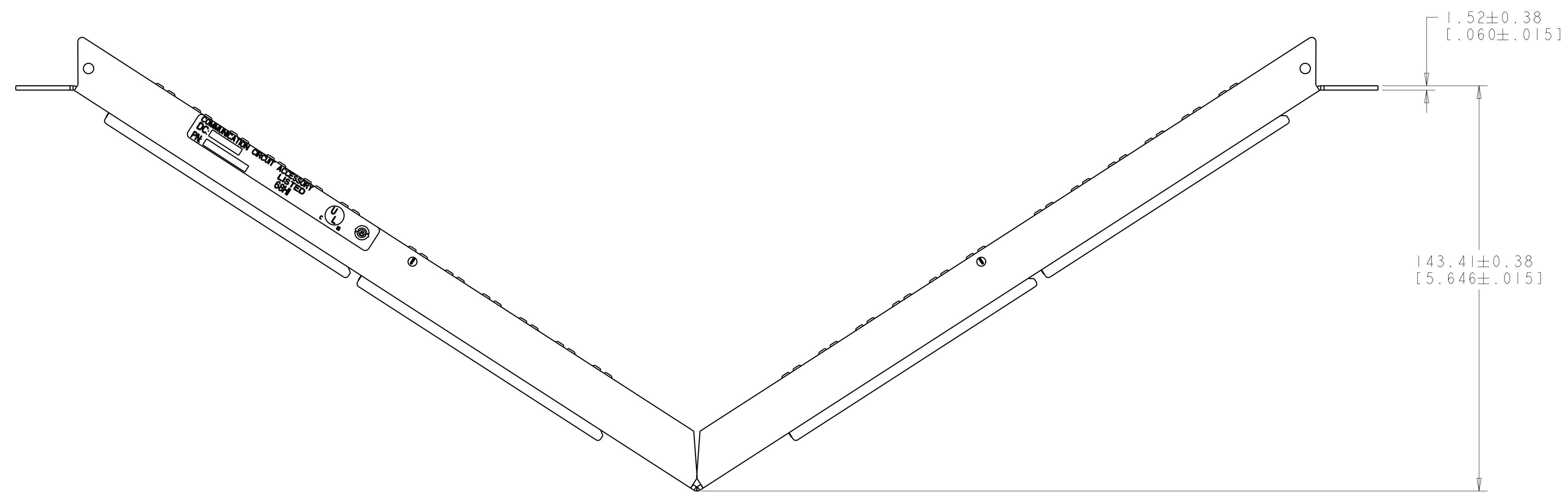

1. MATERIAL:  
 CONNECTOR HOUSING, INTERFACE: POLYESTER MOLDING COMPOUND, BLACK.  
 PANEL: BLACK POWDER COAT STEEL WITH WHITE MARKINGS.  
 AMPTRAC CONTACT : PHOS BRONZE.
2. FOUR BLACK 12-24 X 12.7 [.500] LONG AND FOUR 10-32 X 12.7 [.500] LONG CARBON STEEL CROSS RECESSED SCREWS FOR MOUNTING OF PANEL, SHIPPED LOOSE. NOT SHOWN ON DRAWING.

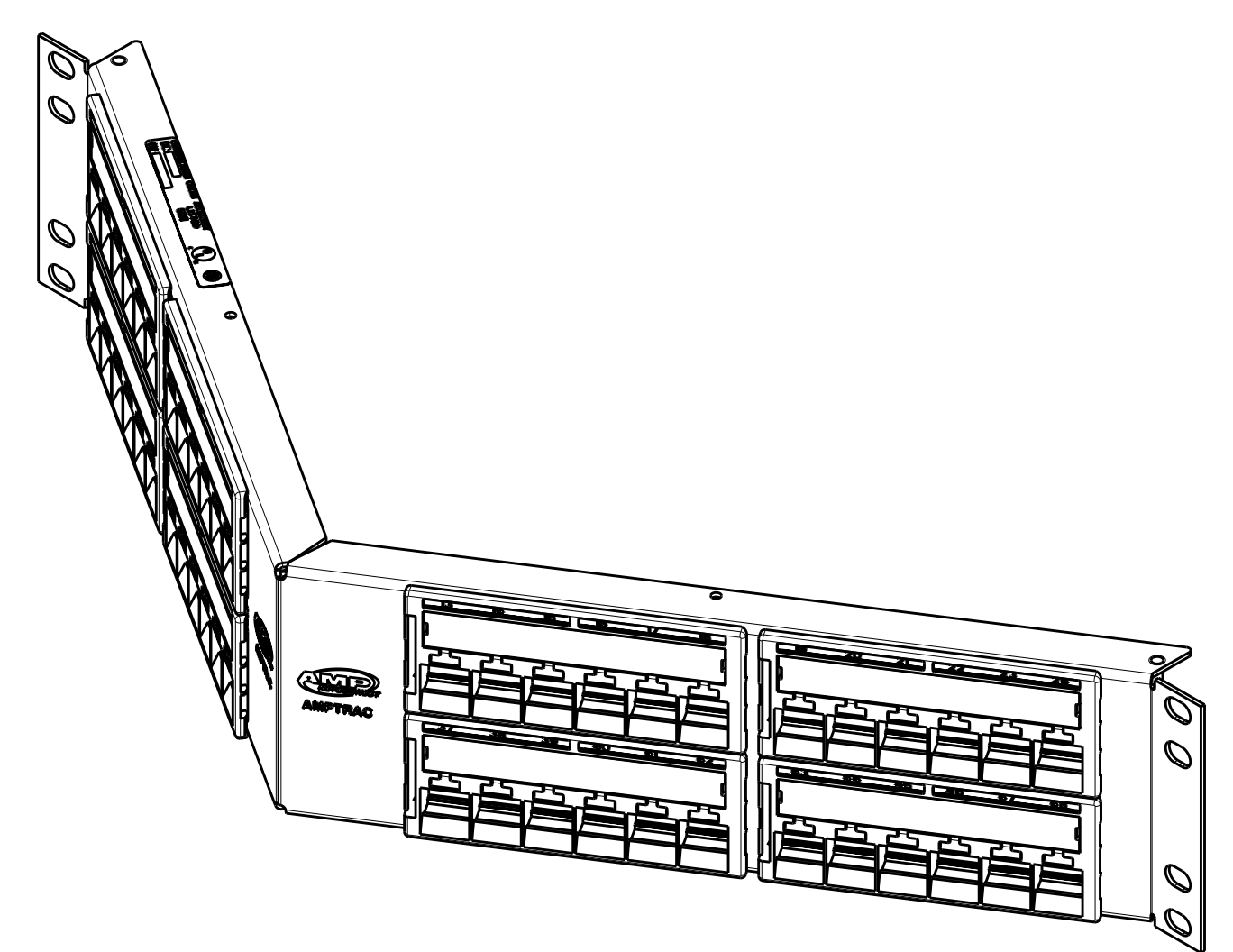
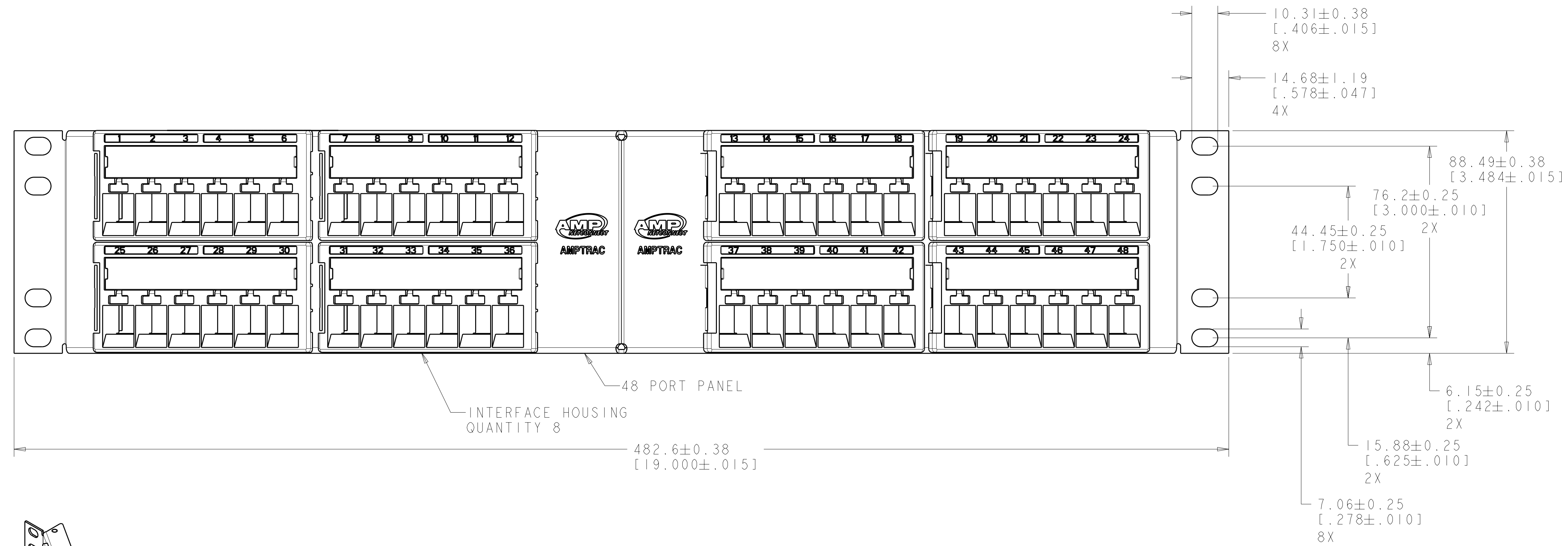

1933326-1  
PART NUMBER

DIMENSIONS: MM [INCHES] 		TOLERANCES UNLESS OTHERWISE SPECIFIED: 9 PLC ± 1 PLC ± 2 PLC ± 3 PLC ± 4 PLC ± ANGLES ±		DWN J MCNEAL 23MAY2007 CHK S HERNDON 23MAY2007 APVD S HERNDON 23MAY2007	Tyco Electronics Harrisburg, PA 17105-3608
MATERIAL:		FINISH:		NAME: KIT, PATCH PANEL, AMPTRAC 2U, 48 PORT, SHLD, MM, FLAT	RESTRICTED TO:
CUSTOMER DRAWING		SIZE: A1 CAGE CODE: 00779 DRAWING NO: C=1933326	SCALE: 1:2	SHEET: 1 OF 1	REV: C